



INTERNATIONAL APPLICATION PUBLISHED UNDER THE PATENT COOPERATION TREATY (PCT)

<p>(51) International Patent Classification ⁶ : H04L 29/06</p>	<p>A1</p>	<p>(11) International Publication Number: WO 95/34153 (43) International Publication Date: 14 December 1995 (14.12.95)</p>
<p>(21) International Application Number: PCT/US95/07301 (22) International Filing Date: 8 June 1995 (08.06.95) (30) Priority Data: 257,670 8 June 1994 (08.06.94) US (71) Applicant: HUGHES AIRCRAFT COMPANY [US/US]; 7200 Hughes Terrace, Los Angeles, CA 90045-0066 (US). (72) Inventor: DILLON, Douglas, M.; 1 Bell Bluff Court, Gaithersburg, MD 20879 (US). (74) Agents: LEITEREG, Elizabeth, E. et al.; Hughes Aircraft Company, 7200 Hughes Terrace, Los Angeles, CA 90045-0066 (US).</p>	<p>(81) Designated States: AM, AT, AU, BB, BG, BR, BY, CA, CH, CN, CZ, DE, DK, EE, ES, FI, GB, GE, HU, JP, KE, KG, KP, KR, KZ, LK, LR, LT, LU, LV, MD, MG, MN, MW, MX, NO, NZ, PL, PT, RO, RU, SD, SE, SI, SK, TJ, TT, UA, UZ, VN, European patent (AT, BE, CH, DE, DK, ES, FR, GB, GR, IE, IT, LU, MC, NL, PT, SE), OAPI patent (BF, BJ, CF, CG, CI, CM, GA, GN, ML, MR, NE, SN, TD, TG), ARIPO patent (KE, MW, SD, SZ, UG).</p> <p>Published <i>With international search report. Before the expiration of the time limit for amending the claims and to be republished in the event of the receipt of amendments.</i></p>	

(54) Title: APPARATUS AND METHOD FOR HYBRID NETWORK ACCESS

(57) Abstract

A system in which a personal computer sends messages into a TCP/IP network using a conventional dial-up link and downloads data from the TCP/IP network using a high-speed one-way satellite link. A preferred embodiment uses a conventional SLIP provider to connect to the TCP/IP network and uses a commercial software TCP/IP package that has a standard driver interface. A spoofing protocol compensates for the long propagation delays inherent to satellite communication.

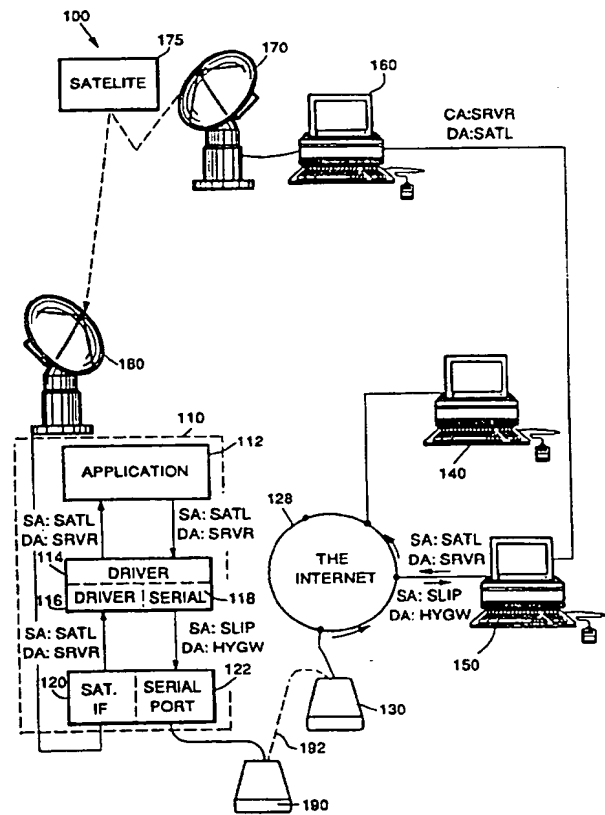

FOR THE PURPOSES OF INFORMATION ONLY

Codes used to identify States party to the PCT on the front pages of pamphlets publishing international applications under the PCT.

AT	Austria	GB	United Kingdom	MR	Mauritania
AU	Australia	GE	Georgia	MW	Malawi
BB	Barbados	GN	Guinea	NE	Niger
BE	Belgium	GR	Greece	NL	Netherlands
BF	Burkina Faso	HU	Hungary	NO	Norway
BG	Bulgaria	IE	Ireland	NZ	New Zealand
BJ	Benin	IT	Italy	PL	Poland
BR	Brazil	JP	Japan	PT	Portugal
BY	Belarus	KE	Kenya	RO	Romania
CA	Canada	KG	Kyrgyzstan	RU	Russian Federation
CF	Central African Republic	KP	Democratic People's Republic of Korea	SD	Sudan
CG	Congo	KR	Republic of Korea	SE	Sweden
CH	Switzerland	KZ	Kazakhstan	SI	Slovenia
CI	Côte d'Ivoire	LI	Liechtenstein	SK	Slovakia
CM	Cameroon	LK	Sri Lanka	SN	Senegal
CN	China	LU	Luxembourg	TD	Chad
CS	Czechoslovakia	LV	Latvia	TG	Togo
CZ	Czech Republic	MC	Monaco	TJ	Tajikistan
DE	Germany	MD	Republic of Moldova	TT	Trinidad and Tobago
DK	Denmark	MG	Madagascar	UA	Ukraine
ES	Spain	ML	Mali	US	United States of America
FI	Finland	MN	Mongolia	UZ	Uzbekistan
FR	France			VN	Viet Nam
GA	Gabon				

APPARATUS AND METHOD FOR HYBRID NETWORK ACCESS

Background of the Invention

This application relates to a computer network and, more specifically, to a method and apparatus for allowing both high-speed and regular-speed access to a computer network.

The Internet is an example of a TCP/IP network. The Internet has over 10 million users. Conventionally, access to the Internet is achieved using a slow, inexpensive method, such as a terrestrial dial-up modem using a protocol such as SLIP (Serial Line IP), PPP, or by using a fast, more expensive method, such as a switched 56 Kbps, frame relay, ISDN (Integrated Services Digital Network), or T1.

Users generally want to receive (download) large amounts of data from networks such as the Internet. Thus, it is desirable to have a one-way link that is used only for downloading information from the network. A typical user will receive much more data from the network than he sends. Thus, it is desirable that the one-way link be able to carry large amounts of data very quickly. What is needed is a high bandwidth one-way link that is used only for downloading information, while using a slower one-way link is used to send data into the network.

Currently, not all users have access to high speed links to networks. Because it will take a long time to connect all users to networks such as the Internet via physical high-speed lines, such as fiber optics lines, it is desirable to implement some type of high-speed line that uses the existing infrastructure.

Certain types of fast network links have long propagation delays. For example, a link may be transmitting information at 10 Mbps, but it may take hundreds of milliseconds for a given piece of information to travel between a source and a destination on the network. In addition, for even fast low-density links, a slow speed return-link may increase the round trip

propagation time, and thus limit throughput. The TCP/IP protocol, as commonly implemented, is not designed to operate over fast links with long propagation delays. Thus, it is desirable to take the propagation delay into account when sending information over such a link.

Summary of the Invention

The present invention overcomes the problems and disadvantages of the prior art by allowing a user to download data using a fast one-way satellite link, while using a conventional low-speed Internet connection for data being sent into the network. The invention uses a "spoofing" technique to solve the problem of the long propagation delays inherent in satellite communication.

In accordance with the purpose of the invention, as embodied and broadly described herein, the invention is a network system that forms a part of a network, comprising: a source computer, having a link to the network; a destination computer, having a link to the network; a satellite interface between the source computer and the destination computer, wherein information passes from the source computer to the destination computer; means in the destination computer for requesting information from the source computer over the network; means for receiving an information packet sent from the source computer in response to the request and for sending the information packet to the destination computer over the satellite interface; and means for sending an ACK message to the source computer in response to receipt of the information packet, wherein the ACK message appears to the source computer to have come from the destination computer.

In further accordance with the purpose of the invention, as embodied and broadly described herein, the invention is a gateway in a network system that forms a part of a TCP/IP network, wherein the network includes a source computer having a link to the TCP/IP network and a link to a high speed satellite interface, and a destination computer having a link to the TCP/IP network and a link to

the high speed satellite interface, the gateway comprising:
means for receiving an information packet sent from the
source computer and for sending the information packet to
the destination computer over the satellite interface; and
5 means for sending an ACK message to the source computer in
response to receipt of the information packet, wherein the
ACK message appears to the source computer to have come
from the destination computer.

Objects and advantages of the invention will be set
10 forth in part in the description which follows and in part
will be obvious from the description or may be learned by
practice of the invention. The objects and advantages of
the invention will be realized and attained by means of the
elements and combinations particularly pointed out in the
15 appended claims.

Brief Description of the Drawings

The accompanying drawings, which are incorporated in
and constitute a part of this specification, illustrate
several embodiments of the invention and, together with the
20 description, serve to explain the principles of the
invention.

Fig. 1 is a hardware block diagram of a preferred
embodiment of the invention;

25 Fig. 2 is a diagram of a portion of a hybrid terminal
of Fig. 1;

Fig. 3 is a diagram showing an IP packet format;

Fig. 4 is a diagram showing a plurality of packet
formats, including an Ethernet packet format;

30 Fig. 5 is a diagram showing a tunnelling packet
format;

Fig. 6 is a diagram of steps performed by the hybrid
terminal of Fig. 1;

Fig. 7 is a diagram showing an example of partial data
in a tunnelling packet;

35 Fig. 8 is a flowchart of steps performed by the hybrid
terminal of Fig. 1;

Fig. 9 is a diagram of steps performed by a hybrid

gateway of Fig. 1;

Fig. 10 is a diagram showing a format of packets sent to a satellite gateway of Fig. 1;

Fig. 11 is a diagram showing a TCP packet format;

5 Fig. 12 is a ladder diagram showing packets sent from an application server to the hybrid gateway and from the hybrid gateway to the hybrid terminal over a satellite link; and

10 Figs. 13(a) through 13(e) are flowcharts of steps performed by the hybrid gateway of Fig. 1.

Detailed Description of the Preferred Embodiments

15 Reference will now be made in detail to the preferred embodiments of the invention, examples of which are illustrated in the accompanying drawings. Wherever possible, the same reference numbers will be used throughout the drawings to refer to the same or like parts.

I. General Overview

20 A preferred embodiment of the present invention uses satellite technology to implement a high-speed one way link between a user's computer and a TCP/IP network, such as the Internet or a private TCP/IP network. This high-speed link is used to download data from the network. The user's computer also has a conventional TCP/IP link for sending data to the network. The invention can use various forms of high-speed, one-way links, such as satellites, and cable television lines. The invention can use various forms of low-speed networks, such as TCP/IP networks, dialup telephones, ISDN D-channel, CPDP, and low-speed satellite paths.

30 The described embodiment of the present invention uses satellites to provide a high-speed one-way link. Satellites can cover large geographical areas and are insensitive to the distance between a transmitter and a receiver. In addition, satellites are very efficient at point-to-point and broadcast applications, and are resilient and resistant to man-made disasters. Two-way satellites are expensive to use, however, because of the

35

costs involved in purchasing and installing satellite earth station hardware. In the past, these costs have placed satellite communications outside the reach of the consumer.

5 The present invention allows a personal computer to receive downloaded information from the network via a satellite at a very practical cost. In the present invention, the cost of satellite communications is reduced because a one-way satellite link is used. Receive-only earth station equipment is cheaper to manufacture because
10 it requires less electronics than send/receive antennae.

As is well-known in the art, communication over the Internet and similar TCP/IP networks is achieved through a group (suite) of protocols called Transmission Control Protocol/Internet Protocol (TCP/IP). The TCP/IP protocol
15 is described in the book "Internetworking With TCP/IP, Vol I" by Douglas Comer, published by Prentice-Hall, Inc., of Englewood Cliffs, N.J., 1991, which is incorporated by reference.

20 II. Hybrid TCP/IP Access

Fig. 1 is a hardware block diagram of a preferred embodiment of the invention. Fig. 1 includes five subsystems: a hybrid terminal 110, a SLIP provider (Internet connection) 130, an application server 140, a hybrid gateway 150, and a satellite gateway 160. Hybrid
25 terminal 110 is connected to a modem 190, e.g., a 9600 baud modem, which connects to SLIP provider 130 through a telephone line 192. A satellite transmitter 170, a satellite 175, and a satellite receiver 180 provide a fast, one-way link for transferring data from satellite gateway
30 160 to hybrid terminal 110. Each of SLIP provider 130, application server 140, and hybrid gateway 150 are connected to the Internet 128. As is well-known in the art, the Internet 128 is a "network of networks" and can be visually depicted only in general terms, as seen in Fig. 1.

35 Each of hybrid terminal 110, SLIP provider 130, application server 140, hybrid gateway 150 and satellite gateway 160 includes a processor (not shown) that executes

instructions stored in a memory (not shown). Other parts of the invention also include processors that are not discussed herein, such as I/O processors, etc. Preferably, hybrid terminal 110, hybrid gateway 150, and satellite gateway 160 are implemented as personal computers including an 80386/80486 based personal computer operating at least 33 MHz, but these elements can be implemented using any data processing system capable of performing the functions described herein. In the described embodiment, SLIP provider 130 is a conventional SLIP provider and application server 140 is any application server that can connect to the Internet via TCP/IP.

As shown in Fig. 1, hybrid terminal 110 preferably includes application software 112, driver software 114, a serial port 122 for connecting hybrid terminal 110 to modem 190, and satellite interface hardware 120 for connecting hybrid terminal 110 to satellite receiver 180.

Fig. 2 shows a relationship between software in application 112, software in driver 114, serial port 122, and satellite interface 120. Application software 112 includes TCP/IP software, such as SuperTCP, manufactured by Frontier, Inc., Chameleon, manufactured by Netmanager, and IRNSS, manufactured by Spry, Inc. The described embodiment preferably operates with the SuperTCP TCP/IP package and, thus, uses a standard interface 212 between the TCP/IP software 210 and driver 114. Examples of standard interfaces 212 between TCP/IP software 210 and driver 114 include the Crynson-Clark Packet Driver Specification and the 3Com/Microsoft Network Driver Interface Specification (NDIS). Other embodiments use other standard or non-standard interfaces between TCP/IP software 210 and driver 114.

As shown in Fig. 2, application software 112 also includes well-known Internet utilities, such as FTP, and well-known user interfaces, such as Mosaic and Gopher (shown). Application software 112 can also include other utilities, e.g., News and Archie (not shown).

The following paragraphs describe how a request from hybrid terminal 110 is carried through the Internet 128 to application server 140 and how a response of application server 140 is carried back to the user at hybrid terminal 110 via the satellite link. The operation of each subsystem will be described below in detail in separate sections.

In the present invention, hybrid terminal 110 is given two IP addresses. One IP packet address corresponds to SLIP provider 130 and is assigned by a SLIP service provider. The other IP address corresponds to satellite interface 120 and is assigned by a hybrid service provider. IP addresses are assigned by the SLIP and satellite network managers and loaded into hybrid terminal 110 as part of an installation configuration of the hybrid terminal's hardware and software. These two IP addresses correspond to completely different physical networks. SLIP provider 130 does not "know" anything about the satellite IP address or even whether the user is using the satellite service. If a host somewhere in the Internet is trying to deliver a packet to the satellite IP address by using the Internet routing scheme of routers, gateways, and ARPs (Address Resolution protocol), the only way that the packet can reach the satellite IP interface is to traverse the satellite by being routed through satellite gateway 160.

The following example assumes that a user at hybrid terminal 110 desires to send a request to a remote machine, such as application server 140, that is running FTP (File Transfer protocol) server software. The FTP software running on application server 140 receives file transfer requests and responds to them in an appropriate fashion.

Fig. 1 shows the contents of a source field (SA) and of a destination field (DA) of packets sent between the elements of Fig. 1. A request for a file and a response of a file sent from application server 140 to hybrid terminal 110 takes the following path.

- 1) Within hybrid terminal 110, FTP client software

230 generates a request and passes it to TCP/IP software 210. TCP/IP software 210 places the request in a TCP packet (see Fig. 11). Next, the TCP packet is placed in an IP packet, having a format shown in Fig. 3. TCP/IP software 210 places the IP packet in an Ethernet packet, as shown in Fig. 4, and passes the Ethernet packet to driver 114. This packet has a source IP address corresponding to satellite interface 120 and a destination IP address of application server 140.

2) In driver 114, the Ethernet header and checksum are stripped off the packet and the IP packet is encapsulated, or "tunneled," inside of another IP packet and sent over serial port 122 to SLIP provider 130. Fig. 5 shows a format of a tunnelled packet. Fig. 7 shows an example of a tunnelled packet. The encapsulation adds a new IP header 530 in front of the original packet 540 with a source address corresponding to SLIP provider 130 and a destination address corresponding to hybrid gateway 150.

3) SLIP provider 130 receives the IP packet, analyzes the tunneling header and, thinking it is destined for hybrid gateway 150, uses standard Internet routing to send the packet to hybrid gateway 150.

4) When hybrid gateway 150 receives the packet, it strips off the tunneling header, revealing the true header with application server 140 as the destination. The packet is then sent back out into the Internet 128.

5) Internet routing takes the packet to application

server 140, which replies with the requested file and addresses the reply to the request's source IP address, i.e., the IP address of the hybrid terminal's satellite interface 120.

5

- 6) In order to find the hybrid terminal's satellite interface 120, the Internet routing protocol will send the packet to the subnet containing a router/gateway connected to hybrid gateway 150. When a router on the same physical network as satellite gateway 160 and hybrid gateway 150 sends out an ARP for the IP address of satellite interface 120 (to find a physical address of satellite interface 120), hybrid gateway 150 responds and says "send it to me." Thus, application server 140 and the rest of the Internet 128 thinks that packets sent to hybrid gateway 150 will reach the hybrid terminal's satellite interface.

10

15

20

- 7) Once hybrid gateway 150 receives a reply packet from application server 140, it sends it to satellite gateway 160. In the described embodiment, hybrid gateway 150 encapsulates the packet in a special packet format that is used over the satellite link and uses the satellite interface IP address to uniquely identify the satellite packet's destination. Then hybrid gateway 150 sends the packet over the Ethernet to satellite gateway 160.

25

30

- 8) Satellite gateway 160 broadcasts over the satellite link any packets it receives from hybrid gateway 150.

35

- 9) Driver 114 in hybrid terminal 110 that services satellite interface 120 scans all packets

broadcast over satellite transmitter 170 looking for its satellite interface IP address in the header. Once it identifies one, it captures it, strips off the satellite header revealing the reply IP packet, and sends it to driver 114.

Thus, IP packets sent into Internet 128 are carried by the SLIP connection, while IP packets from the Internet 128 are carried by the satellite link. The following paragraphs describe the operation of each subsystem in more detail.

10 A. The Hybrid Terminal

Hybrid terminal 110 is the terminal with which the user interacts. Thus, hybrid terminal 110 includes a user interface device (not shown) such as a mouse, keyboard, etc. As shown in Fig. 1, hybrid terminal 110 includes one or more application programs 112 (including TCP/IP software 210), and driver software 114, which communicates with SLIP provider 130 through a serial port 122 and modem 190, using a driver portion 118, and which communicates with satellite receiver 180 through a satellite interface 120, using a driver portion 116.

To TCP/IP software 210, driver 114 appears to be an Ethernet card, although driver 114 is actually connected to satellite receiver 180 (via satellite interface 120) and to SLIP provider 130 (via serial line 122 and modem 190). Thus, TCP/IP software 210 believes that it is communicating with a single physical network, when it is, in reality, communicating with two physical networks (the SLIP dialup network and a satellite network). Ethernet is a packet switching protocol standardized by Xerox Corporation, Intel Corporation, and Digital Equipment Corporation, which is described in "The Ethernet: A Local Area Network Data Link Layer and Physical Layer Specification," September 1980, which is available from any of these three companies, and which is incorporated by reference.

35 Fig. 6 is a diagram of steps performed by driver 114 of hybrid terminal 110 of Fig. 1. As shown in Fig. 6, driver 114 receives packets of data from TCP/IP software

210 and passes them to SLIP provider 130 via serial port 122 and modem 190. A packet sent by application server 140 is received through satellite receiver 180, passed through the satellite interface 120, passed to the satellite driver 220, and passed to driver 114, which passes the received packet to TCP/IP software 210.

The following paragraphs discuss two basic functions performed by driver 114 (tunnelling and ARP handling) and discuss various implementation details for the described embodiment.

1. "Tunnelling"

As discussed above, hybrid terminal 110 has two IP addresses associated with it: one for SLIP provider 130 and one for the satellite interface. Packets containing requests are sent from hybrid terminal 110 to application server 140 via the Internet 128, while packets containing a reply are sent back via the satellite link. Tunnelling is the method by which application server 140 is "fooled" into sending a reply to a different IP address (satellite interface 120) than that of the sender's (serial port 122).

A packet received by driver 114 from the TCP/IP software 210 has a source address of satellite gateway 160 and a destination address of application server 140. As shown in step 610 of Fig. 6, driver 114 removes the Ethernet header and checksum and encapsulates the IP header into an IP tunnelling header having a source address of SLIP provider 130 and a destination address of hybrid gateway 150 (see Fig. 7). As described above, at hybrid gateway 150, the tunnelling header is removed and the packet is sent back into the Internet 128 to be sent to application server 140.

When forming a tunnelling header, driver 114 copies all the values from the old header into the new one with the following exceptions. The source and destination addresses of the tunnelling header change, as described above. In addition, a total packet length field 510 is changed to contain the contents of length field 310 plus

the length of the tunnelling header. Lastly, the driver 114 recalculates checksum 520 of the tunnelling header because some of the fields have changed.

2. ARP Handling

5 ARP (Address Resolution Protocol) is used by TCP/IP to dynamically bind a physical address, such as an Ethernet address, to an IP address. When TCP/IP finds an IP address for which it does not know a physical address, TCP/IP broadcasts an ARP packet to all nodes, expecting a response
10 that tells TCP/IP what physical address corresponds to the IP address.

During initialization, driver 114 declares to TCP/IP software 210 that driver 114 is an Ethernet card to ensure that the packets that TCP/IP package sends are Ethernet
15 packets and that the TCP/IP package will be prepared to receive packets at a high-rate of speed. As shown in step 620 of Fig. 6, when driver 114 detects that TCP/IP has sent an ARP packet, driver 114 creates a physical address and sends a reply packet to TCP/IP software 210. The contents
20 of the physical address are irrelevant, because driver 114 strips off the Ethernet header on packets from TCP/IP before the packets are sent to SLIP provider 130.

3. Other Functions

As shown in step 630 of Fig. 6, packets received by
25 driver 114 from satellite receiver 180 (via satellite driver 114) are merely passed to TCP/IP software 210. The following paragraphs discuss implementation details for the described embodiment.

In a preferred embodiment, TCP/IP software 210 (e.g.,
30 Frontier's SuperTCP) sends an ACK (acknowledge) for every packet it receives, even though this action is not required by the TCP/IP protocol. In this situation, many packets compete for the slow link to SLIP provider 130. In TCP/IP, the ACK scheme is cumulative. This means that when a
35 transmitter receives an ACK stating that the receiver has received a packet with sequence number N, then the receiver has received all packets with sequence numbers up to N as

well, and there is no reason why every packet needs to be ACK'ed.

Fig. 8 is a flowchart of steps performed in a preferred embodiment by driver 114 of hybrid terminal 110. Fig. 11 is a diagram showing a TCP packet format. Fig. 11 includes a sequence number field 1102, an acknowledgment (ACK) number field 1104, and a checksum field 1106. In step 810 of Fig. 8, driver 114 receives an ACK packet with sequence number N from TCP/IP software 210. The packet is queued along with other packets waiting to be sent to SLIP provider 130. In step 820 driver 114 checks to determine whether there is a "run" of sequential packets waiting to be sent. If so, in step 830, driver 114 deletes ACK packets for the same TCP connection that have sequence numbers in the run from the queue and sends an ACK only for the highest sequence number in the run. This action alleviates the bottleneck caused by the relatively slow modem speeds.

Serial port 122 provides a physical connection to modem 190 and, through it, to the terrestrial network via a SLIP protocol as described below in connection with SLIP provider 130. Serial data is sent and received through an RS-232 port connector by a UART (Universal Asynchronous Receiver Transmitter), such as a U8250, which has a one byte buffer and is manufactured by National Semiconductor, or a U16550, which has a 16 byte buffer and is also manufactured by National Semiconductor.

The invention preferably operates under the DOS operating system and Windows, but also can operate under other operating systems.

Satellite driver software 220 receives packets from satellite 180, and passes them to driver 114 using a DOS call. Thus, the two physical links are combined within driver 114 and the existence of two physical links is transparent to TCP/IP software 210. Satellite driver 220 scans all packets transmitted over the satellite channel for a packet with a header corresponding to the IP address

of the satellite interface 122, performs some error detection and correction on the packet, buffers the received packet, and passes the packet to driver 114 using a DOS call, e.g., IOCTL-output-cmd(). Driver 114 copies data from satellite driver 220 as quickly as possible and passes it to TCP/IP software 210.

As discussed above, TCP/IP software 210 is fooled into thinking that it is connected to an Ethernet network that can send and receive at 10 Mbps. This concept is helpful on the receive side because data from the satellite is being received at a high rate. On the transmit side, however, modem 190 is not capable of sending at such a high rate. In addition, TCP/IP software 210 sends Ethernet packets to driver 114, i.e., an IP packet is encapsulated into an Ethernet packet. Because SLIP provider 130 expects IP packets, driver 114 must strip the Ethernet header before the packet is sent to SLIP provider 130.

As described above in connection with Fig. 8, Driver 114 also includes a transmit and receive queue. As data is received from TCP/IP software 210 and received from the satellite driver 220, it is buffered within the queue. When the queue is full, e.g., when TCP/IP is sending packets faster than modem 190 can send them, driver 114 drops the packets and returns an error so that TCP/IP software 210 will decrease its rate of transmission.

In a first preferred embodiment, a SLIP connection is initiated with an automatic logon procedure. In another preferred embodiment, driver 114 executes instructions to allow a user to perform a SLIP logon manually.

Because TCP/IP software 210 preferably is configured to talk to Ethernet and it is desirable to receive the largest packet size possible, driver 114 configures TCP/IP so that the MTU (Maximum Transmission Unit) of the network is as large as possible, e.g., 1500 bytes. Some SLIP providers 130 have a smaller MTU, e.g., 512 bytes. To handle the disparity in size, driver 114 segments large packets received from TCP/IP software 210 into segments the

size of the SLIP MTU. Once a packet is segmented, it is reassembled in hybrid gateway 150. Only the tunnelling header is copied as the header of the segments.

B. The SLIP Provider

5 SLIP provider 130 performs the function of connecting hybrid terminal 110 to the Internet 128. As described above, other protocols, such as PPP, could also be used to perform the connecting function. SLIP server 130 receives SLIP encoded IP packets from modem 190, uncodes them, and
10 forwards them to hybrid gateway 150 via the Internet 128.

In its most basic form, SLIP provider 130 delimits IP packets by inserting a control character hex 0xC0 between them. To insure that a data byte is not mistaken for the control character, all outgoing data is scanned for
15 instances of the control character, which is replaced by a two character string. The SLIP protocol is described in detail in J. Romkey, "A Nonstandard for Transmission of IP Datagrams over Serial Lines: SLIP," RFC 1055, June 1988, pp. 1-6, which is incorporated by reference.

20 C. The Application Server

Application server 140 is a computer system running any combination of known application programs available on the Internet using the TCP/IP protocol suite. For example, application server 140 may be transferring files to
25 requesting users via FTP. Although hybrid terminal 110 actually has two IP addresses (a serial port address and an address for the satellite interface), the software executing on application server 140 thinks that it is receiving requests over the satellite network and sending
30 responses over the satellite network. Hybrid terminal 110 is completely transparent to application server 140.

D. The Hybrid Gateway

Although only one hybrid terminal 110 is shown in Fig. 1, the invention can include a plurality of hybrid
35 terminals 110. Preferably, all packets sent from all hybrid terminals 110 pass through hybrid gateway 150 to get untunnelled. Thus, hybrid gateway 150 is a potential

system bottleneck. Because of this potential bottleneck, the functions of hybrid gateway 150 are as simple as possible and are performed as quickly as possible. Hybrid gateway 150 also has good Internet connectivity to minimize the accumulated delay caused by packets waiting to be processed by hybrid gateway 150.

1. Untunnelling

Fig. 9 is a diagram of steps performed by hybrid gateway 150 of Fig. 1. In step 910, hybrid gateway 150 receives a tunnelled packet having a format shown in Fig. 5. Hybrid gateway 150 "untunnels" the packet by stripping off the tunnelling header and passes the packet back to the Internet.

As described above, packets are sometimes broken into segments when they are sent in order to accommodate a small MTU of SLIP provider 130. Packets may also be segmented as they pass through other elements of the net having small MTUs. For fragmented packets, only the tunnelled header is copied into the header of each segment. Hybrid gateway 150 stores fragmented packets in a memory (not shown) and reassembles them in order before untunnelling the original packet and passing it to the Internet. Preferably, a "time to live" value is assigned to each packet when it is sent by driver 114 and if all segments do not arrive before a time to live timer expires, the packet is discarded.

2. ARP Responding

Preferably, satellite gateway 160 is on a same physical network as hybrid gateway 150. As shown in step 920 of Fig. 9, when a router on the same physical network as satellite gateway 160 and hybrid gateway 150 sends out an ARP for the IP address of satellite gateway 160 (to find a physical address of satellite gateway 160), hybrid gateway 150 responds and says "send it to me." Hybrid gateway 150 needs to intercept packets intended for satellite gateway 160 because it needs to encapsulate packets for satellite gateway 160 as follows.

3. Satellite Packetizing

The following paragraphs describe how packets travel from application server 140 through hybrid gateway 150 and to satellite gateway 160. The following explanation is given by way of example and is not intended to limit the scope of the present invention. As shown in step 930 of Fig. 9, hybrid gateway 150 encapsulates replies from application server 140 into a satellite packet format. Fig. 10 is a diagram showing a format of a satellite packet sent to satellite gateway 160 of Fig. 1. A satellite packet includes the data 1010 of an original IP packet and two headers added by hybrid gateway 150.

Satellite gateway 160 expects IP packets to be encapsulated first in a special satellite packet and then within an LLC-1 IEEE 802.2 link level control, type 1 packet. Satellite header 1020 identifies the downlink and contains a sequence number and the packet length. An LLC-1 header 1030 preferably is used to send the packet to satellite gateway 160, in an Ethernet LAN. Hybrid gateway 150 prepares packets for satellite gateway 160 by appending headers 1020 and 1030 to the front of an IP packet 1010.

The receiver in hybrid terminal 110 does not receive the LLC-1 header 1030. Hybrid terminal 110 identifies packets intended for it by checking a least significant byte in the satellite IP address. Thus, a six byte satellite destination address is determined by reversing an order of bytes of the satellite IP address for hybrid terminal 110 and then padding the rest of the address with zeroes.

E. The Satellite Gateway

Satellite gateway 160 can include any combination of hardware and software that connects satellite transmitter 170 to hybrid gateway 150. Satellite transmitter 170 and satellite receiver 180 can be any combination of hardware and software that allows data to be transmitted by satellite transmitter 170 and received by satellite receiver 180, and to be input to hybrid terminal 110. For example, satellite gateway 160 preferably is a personal

computer with a high-speed Ethernet connection to hybrid terminal 110. When satellite gateway 160 receives a packet from hybrid gateway 150, it sends it over the satellite link.

5 Satellite communication may be effected by, for example, the Personal Earth station manufactured by Hughes Network Systems Corp. In a preferred embodiment, a one-way version of the Personal Earth Station is used. Another
10 embodiment uses a satellite communication system manufactured by Comstream. Yet another embodiment uses a system that allows hybrid terminal 110 to be connected directly to satellite receiver 180 via Hughes Network Systems' DirectPC product. The DirectPC satellite
15 interface card is described in "DirectPC, Phase A Data Sheet," dated June 7, 1993, which is attached as Appendix A, which is incorporated in and constitutes a part of this specification, and which is incorporated by reference.

 At the downlink, satellite receiver 180 includes a 0.6 meter receive-only antenna receiving HDLC encapsulated LAN
20 packets. Satellite interface 120 includes rate 2/3 Viterbi/Reed-Soloman concatenated forward error correction.

 Although only one hybrid terminal 110 and one application server 140 are shown in Fig. 1, the invention can include a plurality of hybrid terminals 110 and/or a
25 plurality of application servers 140. Preferably, all packets sent from all application servers 140 to a hybrid interface 110 pass through satellite gateway 160. Thus, satellite gateway 160 is a potential system bottleneck. Because of this potential bottleneck, the functions of
30 satellite gateway 160 are as simple as possible and are performed as quickly as possible.

III. Protocol Spoofing

 TCP/IP protocol specifies that only a predetermined number of packets can be outstanding during transmission,
35 i.e., that only a limited number of packets can be sent before an ACK (acknowledgment) is received. The high bandwidth and long delays incurred in sending packets to an

orbiting satellite and back means that at any given time, a lot of packets are "in the pipe" between transmitter and receiver.

When using conventional TCP/IP protocol, application server 140 sends a predetermined number of packets in accordance with a predetermined window size, and then waits to receive ACKs over the modem link before sending additional packets. The purpose of windowing is to limit a number of packets that must be re-sent if no ACK is received and to provide flow control, e.g., to prevent sending packets faster than they can be received. The packets that have not been ACK'ed are stored in a memory so that they can be re-sent if no ACK is received.

In a preferred embodiment of the present invention, hybrid gateway 150 "spoofs" application server 140 to improve the throughput over the satellite link. Specifically, hybrid gateway 150 sends an ACK to application server 140, even though a corresponding packet may not have been received by hybrid terminal 110 via the satellite at the time.

Fig. 12 is a ladder diagram showing packets sent from application server 140 to hybrid gateway 150 and from hybrid gateway 150 to hybrid terminal 110 through the satellite link. Fig. 12 is not drawn to scale. In Fig. 12, application server 140 sends a message #1 to hybrid gateway 150. The propagation time for this transmission is relatively short. Hybrid gateway 150 immediately creates an ACK packet and sends it to application server 140. Hybrid gateway also sends packet #1 to hybrid terminal 110 through the satellite link. This transmission has a long propagation delay. When hybrid terminal 110 receives the packet, it sends an ACK #1 back to hybrid gateway 150 (e.g., using the tunnelling mechanism described above). In a system that does not use tunnelling, hybrid gateway 150 needs to intercept the ACK packets from hybrid terminal 110.

Figs. 13(a) through 13(e) are flowcharts of steps

performed by hybrid gateway 150 of Fig. 1 during protocol spoofing. In step 1302 of Fig. 13(a), hybrid gateway 150 receives a packet from application server 140 indicating that a new connection is being formed between application server 140 and hybrid terminal 110. In step 1304, hybrid gateway 150 sets up a queue or similar data structure in memory to save un-ACK'ed packets for the new connection. Fig. 13(b) show corresponding steps performed by hybrid gateway 150 when the connection is closed. Hybrid gateway 150 receives a packet indicating the closure in step 1306 and deletes the queue and saved values for the connection in step 1308.

In step 1310 of Fig. 13(c), hybrid gateway 150 fails to receive an ACK for a packet number X from hybrid terminal 110 before an end of a predetermined timeout period. Hybrid gateway 150 maintains a timer for each un-ACK'ed packet. At the end of the predetermined period, hybrid gateway 150 retransmits a packet corresponding to the expired timer. In step 1312, hybrid gateway 150 re-sends packet number X, which it previously saved in the memory queue for this connection (see Fig. 13(d) below).

In step 1314 of Fig. 13(d), hybrid gateway 150 receives a packet from application server 140. In step 1316, hybrid gateway 150 sends the received packet to satellite gateway 160, where it is transmitted over the satellite link, and saves the packet in case it needs to be retransmitted (see Fig. 13(c)). Hybrid gateway 150 then creates an ACK packet to send to application server 140 in step 1318. The created ACK packet incorporates a format shown in Fig. 11. Hybrid gateway 150 creates an ACK number for field 1104. The ACK number is determined as follows:

Hybrid gateway 150 saves the following information for each connection:

- 1) Send sequence number - a highest in-sequence sequence number of packets sent by application server 140 over the connection.
- 2) ACK sequence number - the ACK sequence number from

the most recent packet sent by hybrid terminal 110 over this connection.

3) ACK window size - the window size from the most recent packet from hybrid terminal 110 over this connection.

4) ACK number - the ACK sequence number that is relayed to application server 140. The ACK number is set to:

10 minimum(send sequence number, ACK sequence number + spoofed window size - ACK window size).

5) spoofed window size - predetermined maximum number window size to be allowed on this connection.

15 When hybrid gateway 150 inserts the ACK number in the packet, it also calculates the packet's checksum 1106.

20 In step 1320 of Fig. 13(e), hybrid gateway 150 receives an ACK packet over the modem link from hybrid terminal 110. In step 1322, hybrid gateway 150 removes from the queue the packet for which the ACK was received. Because an ACK was received, the packet does not need to be re-sent. In the TCP/IP protocol, a packet containing an ACK may or may not contain data. Hybrid gateway 150 edits the received packet to replace the packet's ACK number 1104

25 with a "spoofed" ACK number in step 1326. The spoofed ACK number is determined in the same way as the ACK number in step 1318 of Fig. 13(d). When hybrid gateway 150 substitutes the spoofed ACK number 1104 in the packet, it also recalculates the packet's checksum 1106 in step 1326.

30 In step 1328, hybrid gateway 150 forwards the received ACK packet to application server 140. Application server 140 may simply disregard the packet if it contains an ACK and no data. In another embodiment, hybrid gateway 150 simply discards a packet received from hybrid terminal 110

35 that contains an ACK, but no data.

If the connection goes down, either explicitly or after a predetermined period of time, hybrid gateway 150

deletes the saved packets for the connection.

IV. Summary

In summary, the present invention allows a personal
5 computer to send messages into the Internet using a
conventional dial-up link and to download data from the
Internet using a high-speed one-way satellite link. In a
preferred embodiment, the invention uses a conventional
SLIP provider to connect to the Internet and uses a
10 commercial software TCP/IP package that has a standard
driver interface. A spoofing protocol compensates for the
long propagation delays inherent to satellite
communication.

Other embodiments will be apparent to those skilled in
the art from consideration of the specification and
practice of the invention disclosed herein. It is intended
that the specification and examples be considered as
exemplary only, with a true scope of the invention being
indicated by the following claims.

WHAT IS CLAIMED IS:

1. A network system that forms a part of a network, comprising:

5 a source computer, having a link to the network;
a destination computer, having a link to the network;

a satellite interface between the source computer and the destination computer, wherein information passes from the source computer to the destination computer;

10 means in the destination computer for requesting information from the source computer over the network;

means for receiving an information packet sent from the source computer in response to the request and for sending the information packet to the destination computer over the satellite interface; and

15 means for sending an ACK message to the source computer in response to receipt of the information packet, wherein the ACK message appears to the source computer to have come from the destination computer.

2. The network of claim 1, further comprising means for receiving a packet containing an ACK message from the destination computer, for indicating receipt of the information packet by the destination computer, and for
5 discarding the ACK message received from the destination computer when no other data is present in the received packet.

3. The network of claim 1, further comprising means for receiving a packet containing an ACK message from the destination computer, for indicating receipt of the information packet by the destination computer, and for
5 editing the ACK message and passing the received packet to the source computer.

4. The network of claim 3, wherein the editing means includes means for editing an ACK number of the received packet and for adjusting a checksum of the received packet in accordance with the edited value.

5. The network of claim 1, wherein the information packet is formatted in accordance with TCP/IP protocol.

6. The network of claim 1, wherein the ACK message is formatted in accordance with TCP/IP protocol.

7. The network of claim 1, wherein the satellite interface is a one-way interface.

8. A gateway in a network system that forms a part of a TCP/IP network, wherein the network includes a source computer having a link to the TCP/IP network and a link to a high speed satellite interface, and a destination computer having a link to the TCP/IP network and a link to the high speed satellite interface, the gateway comprising:

5 means for receiving an information packet sent from the source computer and for sending the information packet to the destination computer over the satellite interface; and
10

means for sending an ACK message to the source computer in response to receipt of the information packet, wherein the ACK message appears to the source computer to have come from the destination computer.

9. The gateway of claim 8, further comprising means for receiving a packet containing an ACK message from the destination computer, for indicating receipt of the information packet by the destination computer, and for discarding the ACK message from the destination computer when no other data is present in the received packet.
5

10. The gateway of claim 8, further comprising means for receiving a packet containing an ACK message from the destination computer, for indicating receipt of the information packet by the destination computer, and for editing the ACK message and passing the received packet to the source computer.
5

11. The gateway of claim 10, wherein the editing means includes means for editing an ACK number of the received packet and for adjusting a checksum of the received packet in accordance with the edited value.

12. The gateway of claim 8, wherein the information packet is formatted in accordance with TCP/IP protocol.

13. The gateway of claim 8, wherein the ACK message is formatted in accordance with TCP/IP protocol.

14. A method for sending information over a high speed satellite interface in a network system that forms a part of a TCP/IP network, wherein the network includes gateway and a source computer, having a link to the TCP/IP network, a destination computer, having a link to the TCP/IP network, and a satellite interface between the source computer, the gateway, and the destination computer, wherein information passes from the source computer to the destination computer, the method comprising the steps, performed by a processor of the gateway, of:

receiving an information packet sent from the source computer;

sending the information packet to the destination computer over the satellite interface; and

sending an ACK message to the source computer in response to receipt of the information packet, wherein the ACK message appears to the source computer to have come from the destination computer.

15. The method of claim 14, further comprising the steps of receiving a packet containing an ACK message from the destination computer, wherein the ACK message indicates receipt of the information packet by the destination computer and discarding the ACK message from the destination computer when no other data is present in the received packet.

16. The method of claim 14, further comprising the steps of receiving a packet containing an ACK message from the destination computer, wherein the ACK message indicates receipt of the information packet by the destination computer, and editing the ACK message and passing the received packet to the source computer.

17. The method of claim 16, wherein the editing step includes the substeps of editing an ACK number of the

received packet and adjusting a checksum of the received packet in accordance with the edited value.

18. The method of claim 14, wherein the information packet is formatted in accordance with TCP/IP protocol.

19. The method of claim 14, wherein the ACK message is formatted in accordance with TCP/IP protocol.

FIG. 1.

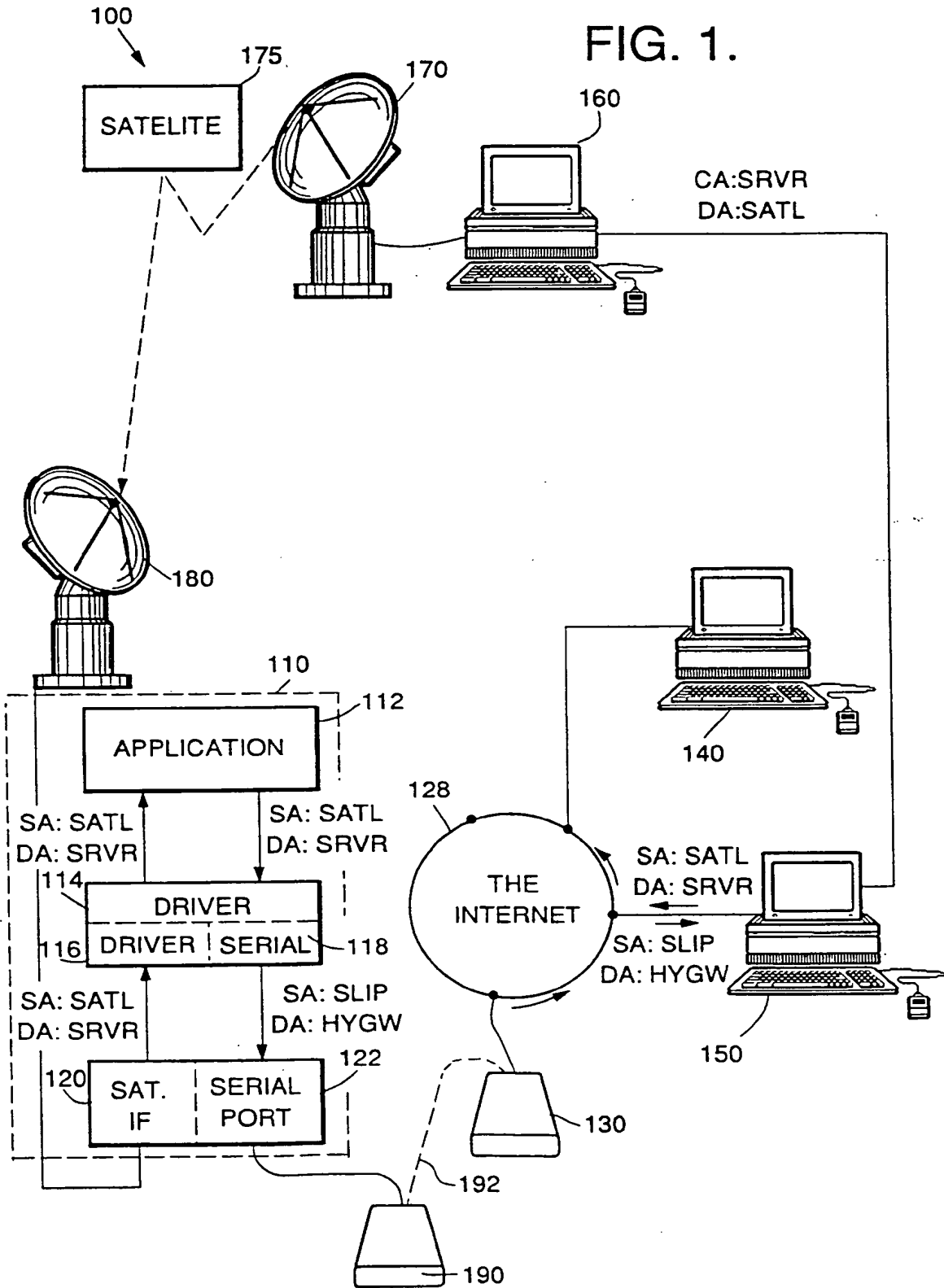

FIG. 2.

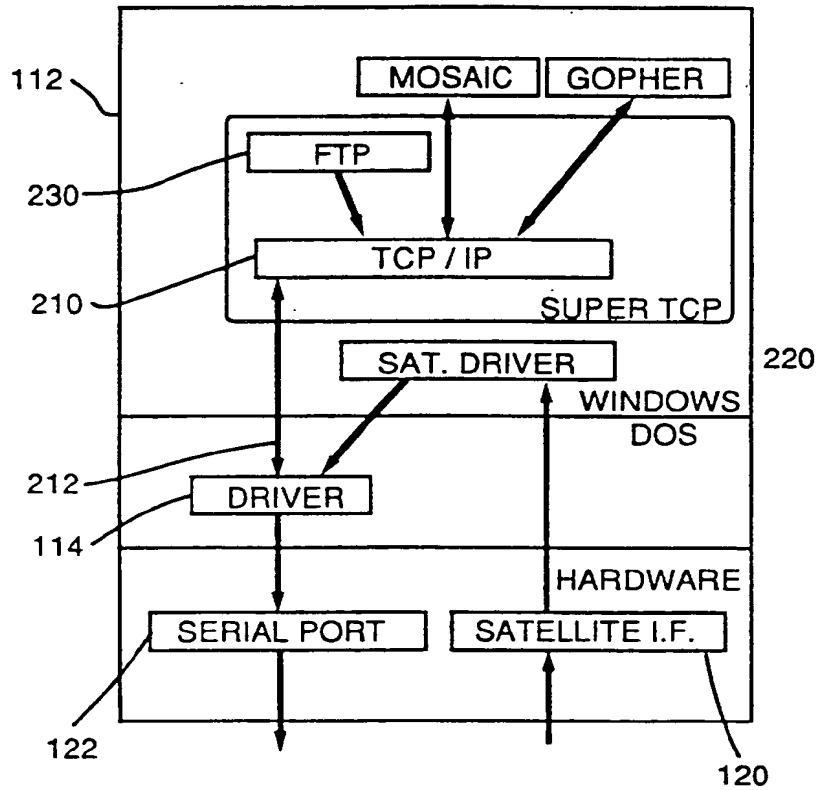

FIG. 3.

NORMAL PACKET

VERS	HIEN	SERVICE TYPE	TOTAL PACKET LENGTH	
IDENTIFICATION NUMBER			FLAGS	FRAGMENT OFFSET
TIME TO LIVE	PROTOCOL		HEADER CHECKSUM	
SOURCE IP ADDRESS				
DESTINATION IP ADDRESS				
IP OPTIONS (IF ANY)				PADDING
DATA				

BIT 0

BIT 22

FIG. 4.

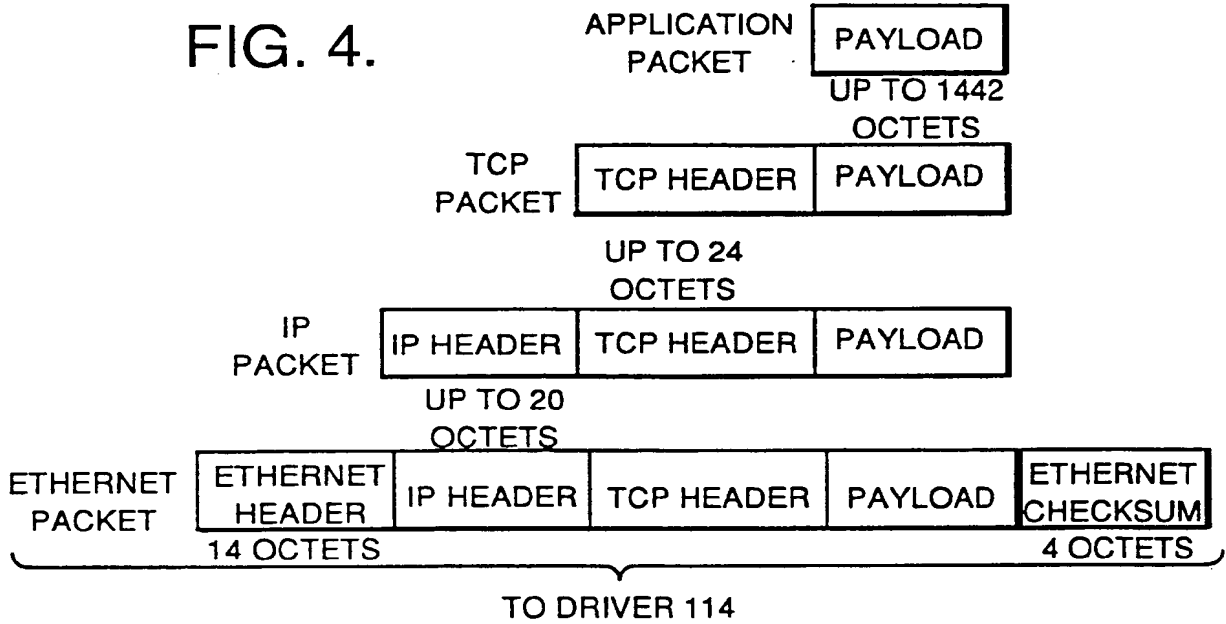
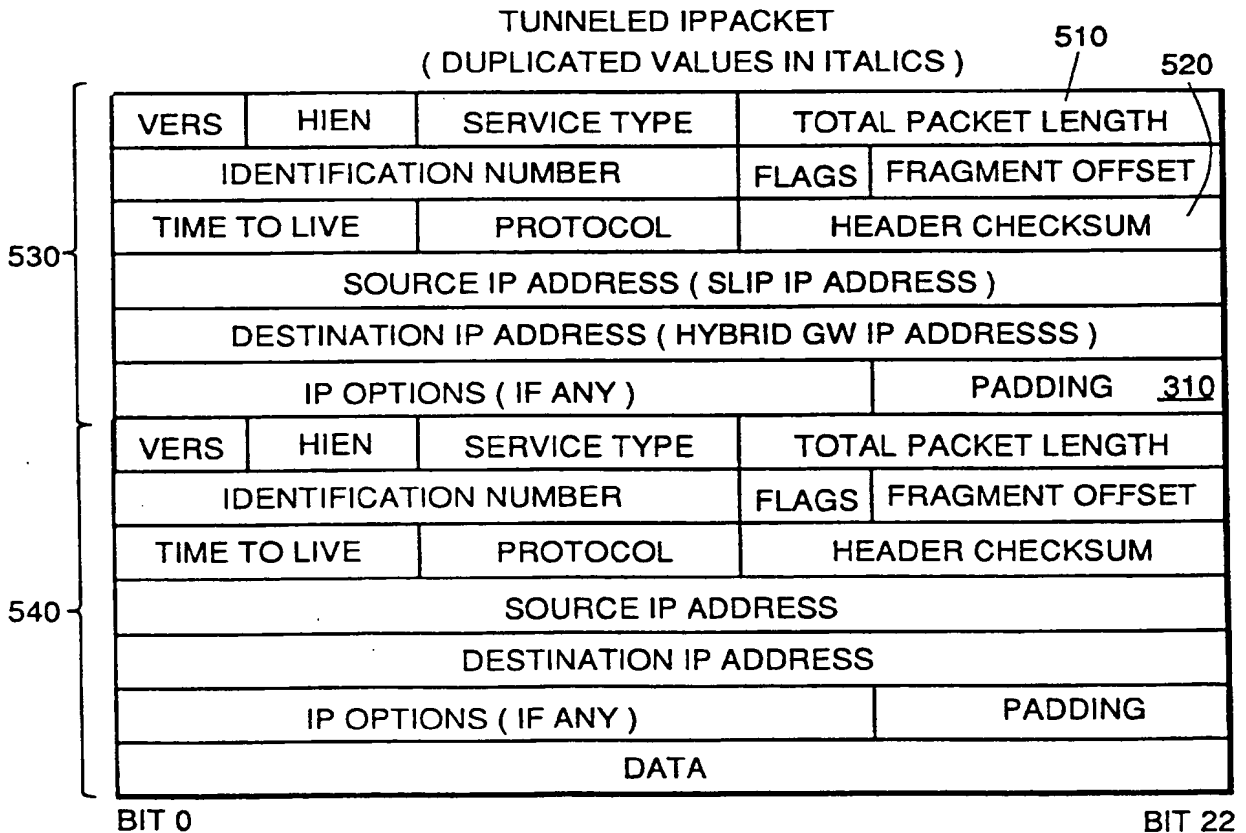

FIG. 5.



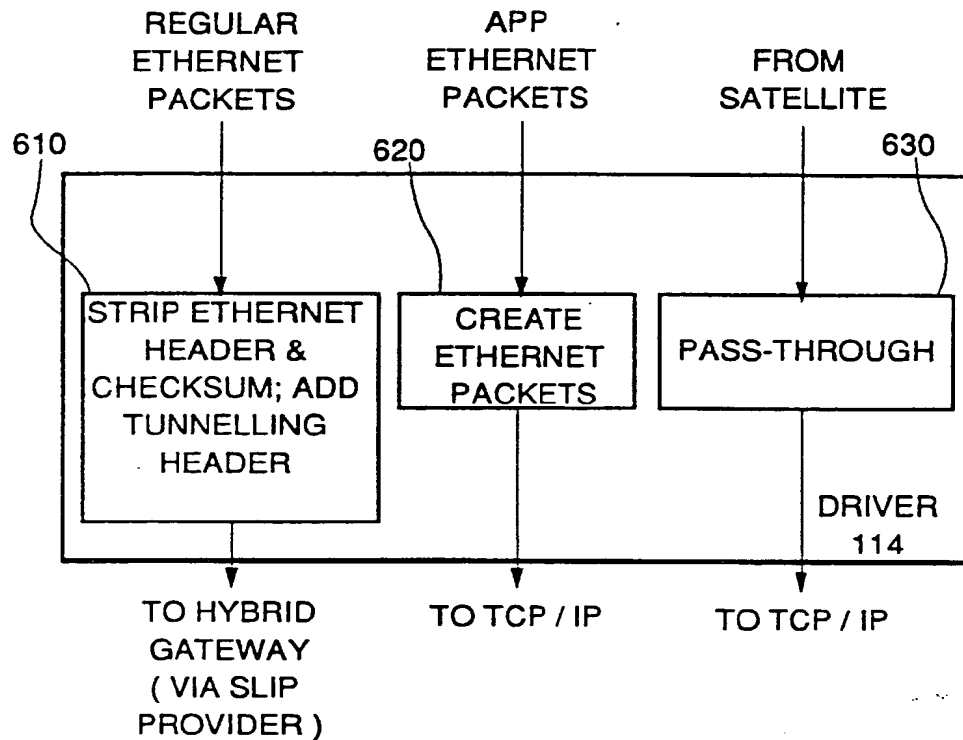

FIG. 6.

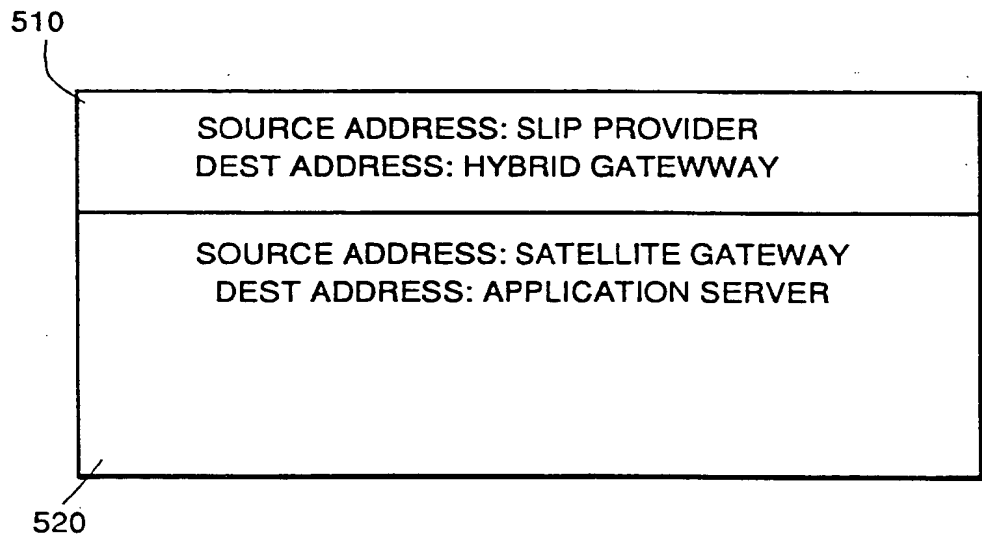

FIG. 7.

FIG. 8.

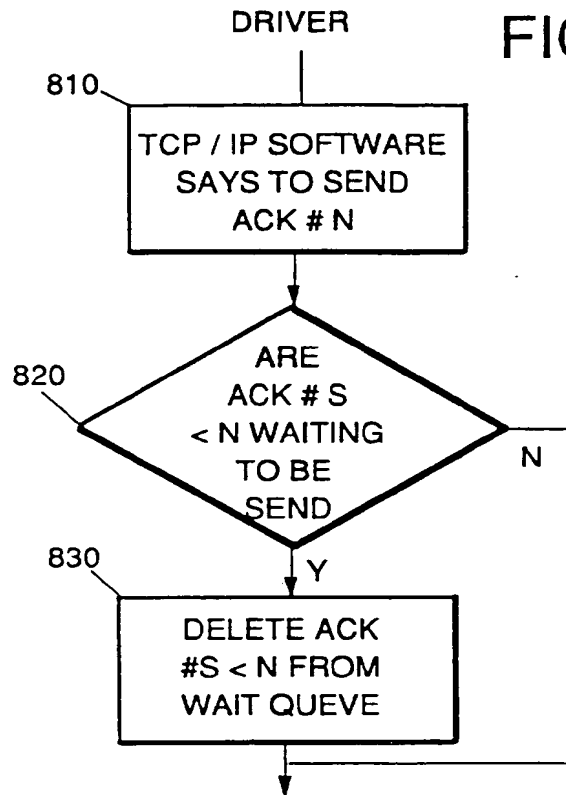

FIG. 9.

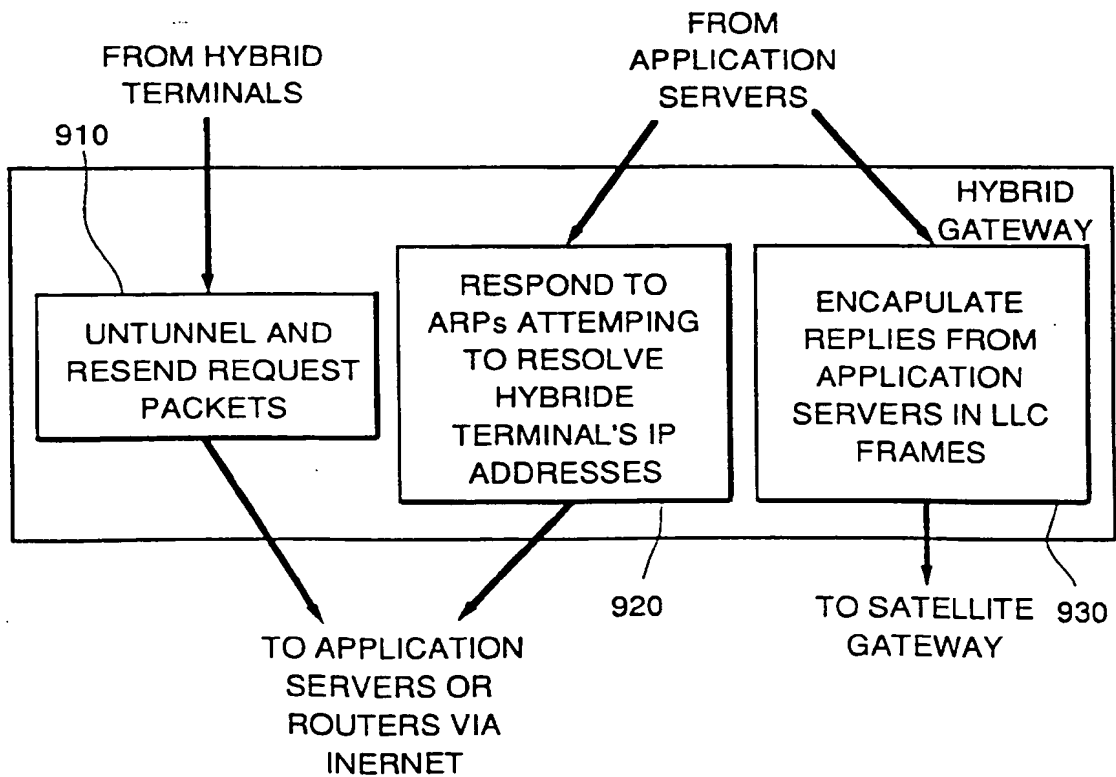

FIG. 10.

1030	1020	1010
LLC HEADER	SATELLITE HEADER	IP DATAGRAM (PAYLOAD)
DELIVERS PACKET TO SATELLITE GATEWAY STRIPPED OFF IN SATELLITE GATEWAY	USED TO ID CORRECT RECEIVER TERMINAL STRIPPED OFF IN BIC DRIVER IN USER TERMINAL	DESTINED FOR TCP/IP PACKAGE IN USER TERMINAL

FIG. 11.

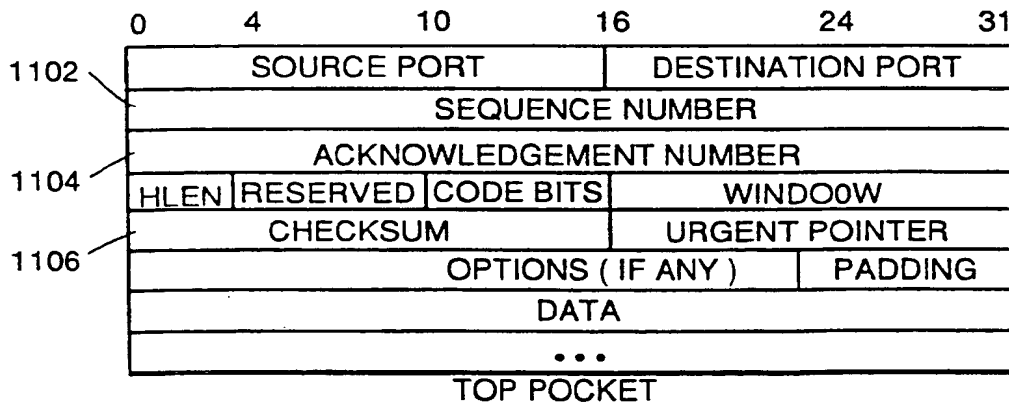

FIG. 12.

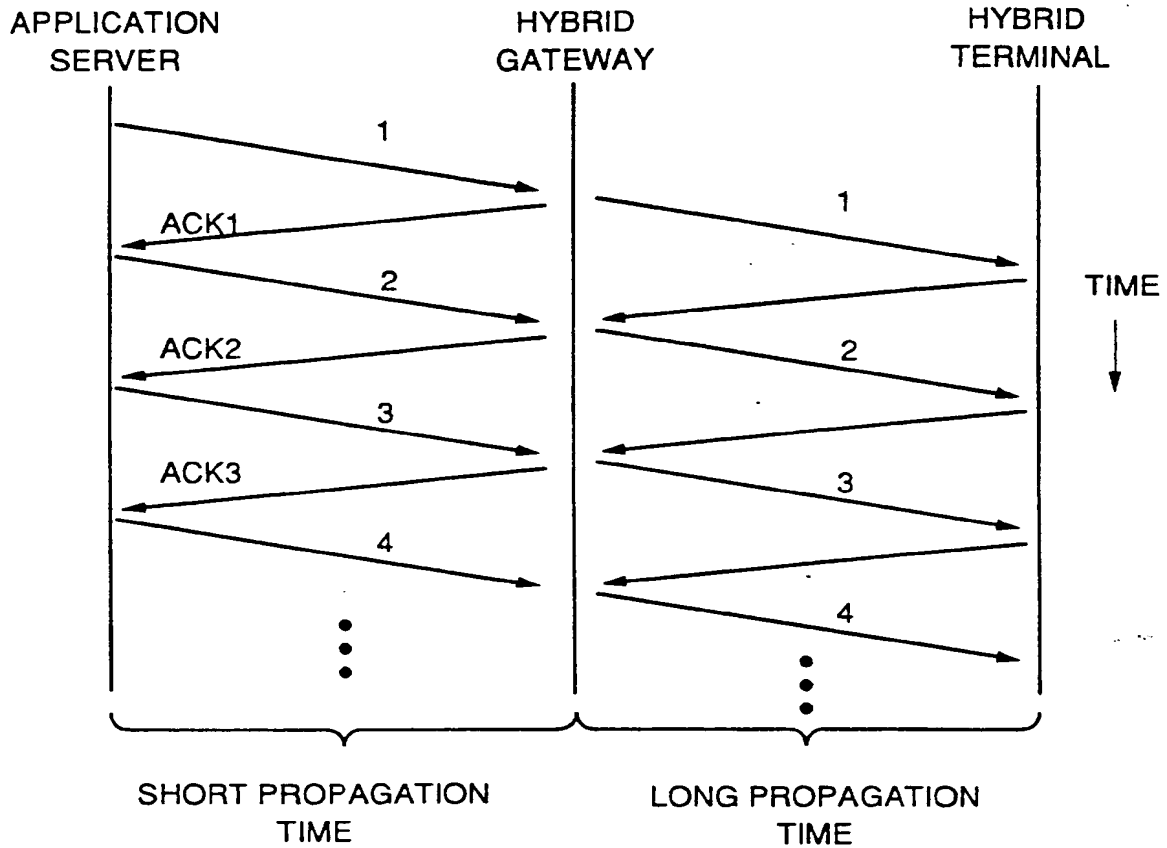

FIG. 13a.

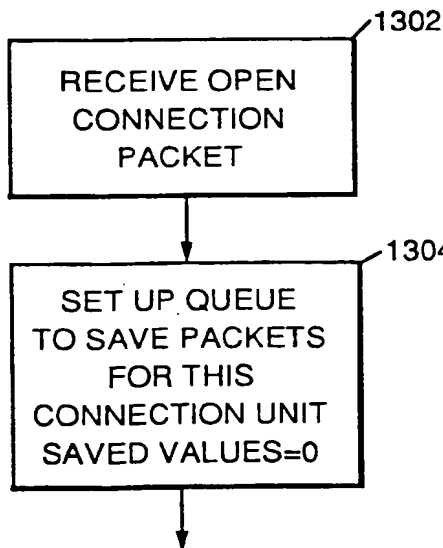

FIG. 13b.

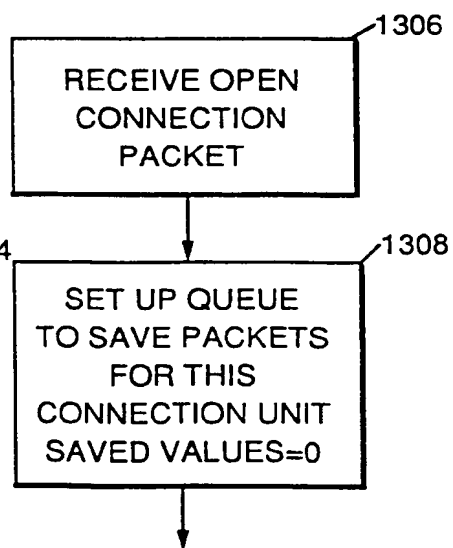

FIG. 13c.

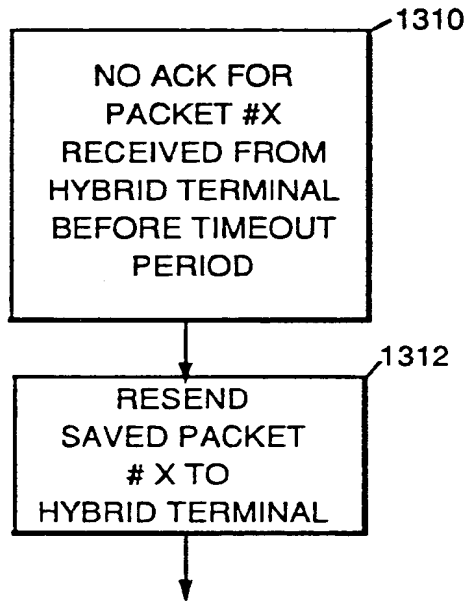

FIG. 13d.

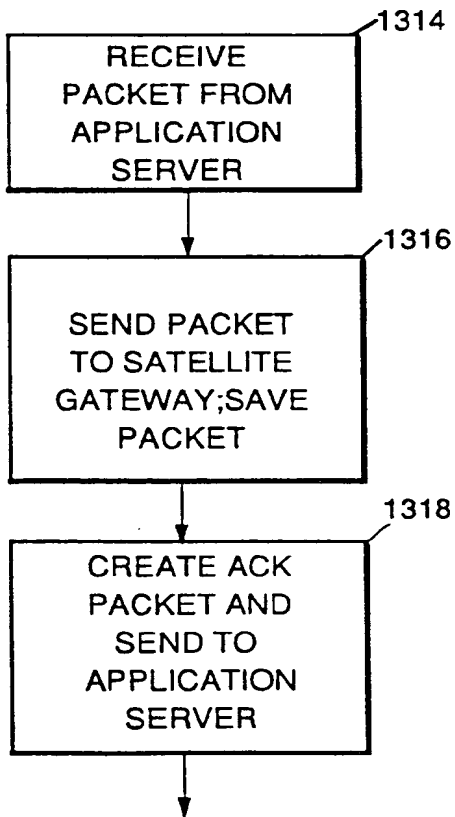
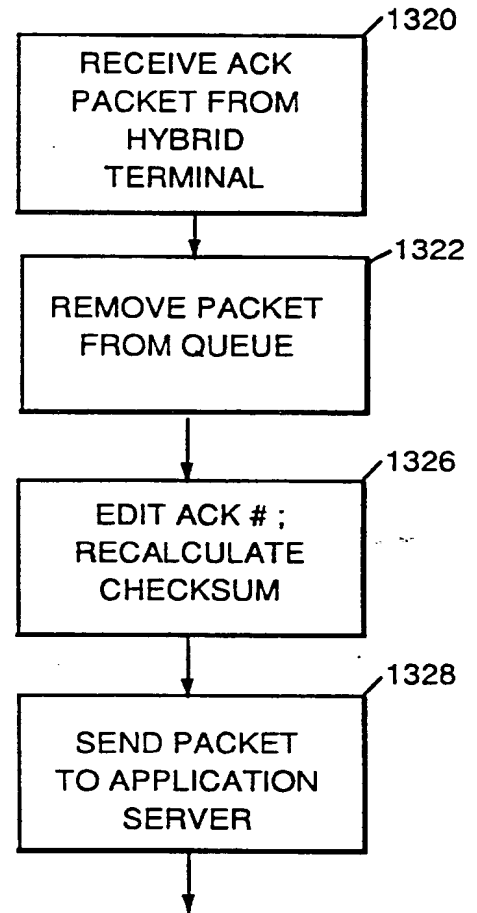

FIG. 13e.



INTERNATIONAL SEARCH REPORT

Internat. Application No

PCT/US 95/07301

A. CLASSIFICATION OF SUBJECT MATTER
IPC 6 H04L29/06

According to International Patent Classification (IPC) or to both national classification and IPC

B. FIELDS SEARCHED

Minimum documentation searched (classification system followed by classification symbols)

IPC 6 H04L

Documentation searched other than minimum documentation to the extent that such documents are included in the fields searched

Electronic data base consulted during the international search (name of data base and, where practical, search terms used)

C. DOCUMENTS CONSIDERED TO BE RELEVANT

Category *	Citation of document, with indication, where appropriate, of the relevant passages	Relevant to claim No.
X	US,A,4 793 813 (D.L.BITZER ET AL) 27 December 1988 see column 2, line 3 - line 18 see column 2, line 56 - column 3, line 40 see column 3, line 66 - column 6, line 13 see claims 1,2 see abstract see figures 1,2	1,2,7
Y	---	5,6,8,9, 12-15, 18,19
Y	EP,A,0 483 547 (IBM) 6 May 1992 see column 4, line 19 - line 55 see abstract -----	5,6,8,9, 12-15, 18,19

Further documents are listed in the continuation of box C.

Patent family members are listed in annex.

* Special categories of cited documents :

- *A* document defining the general state of the art which is not considered to be of particular relevance
- *E* earlier document but published on or after the international filing date
- *L* document which may throw doubts on priority claim(s) or which is cited to establish the publication date of another citation or other special reason (as specified)
- *O* document referring to an oral disclosure, use, exhibition or other means
- *P* document published prior to the international filing date but later than the priority date claimed

- *T* later document published after the international filing date or priority date and not in conflict with the application but cited to understand the principle or theory underlying the invention
- *X* document of particular relevance; the claimed invention cannot be considered novel or cannot be considered to involve an inventive step when the document is taken alone
- *Y* document of particular relevance; the claimed invention cannot be considered to involve an inventive step when the document is combined with one or more other such documents, such combination being obvious to a person skilled in the art.
- *&* document member of the same patent family

Date of the actual completion of the international search

12 September 1995

Date of mailing of the international search report

06.10.95

Name and mailing address of the ISA
European Patent Office, P.B. 5818 Patentlaan 2
NL - 2280 HV Rijswijk
Tel. (+31-70) 340-2040, Tx. 31 651 epo nl,
Fax (+31-70) 340-3016

Authorized officer

Canosa Areste, C

INTERNATIONAL SEARCH REPORT

Information on patent family members

Internationa	Application No
PCT/US 95/07301	

Patent document cited in search report	Publication date	Patent family member(s)	Publication date
US-A-4793813	27-12-88	AU-B- 587653	24-08-89
		AU-A- 6483886	12-05-88
		BE-A- 905778	16-03-87
		CH-A- 672553	30-11-89
		DE-A- 3638675	19-05-88
		FR-A- 2607285	27-05-88
		GB-A- 2196761	05-05-88
		JP-A- 63131731	03-06-88
		SE-B- 456288	19-09-88
		SE-A- 8604596	29-04-88
EP-A-0483547	06-05-92	US-A- 5159592	27-10-92
		JP-A- 4227149	17-08-92